

3.5 mm DUAL STEREO JACK

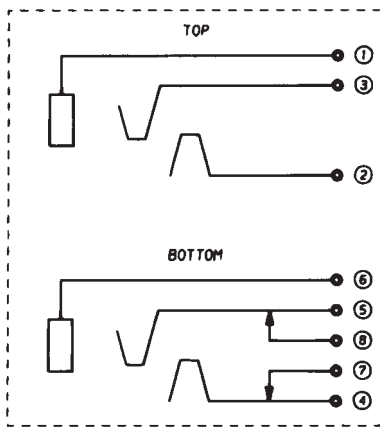

SCHEMATIC

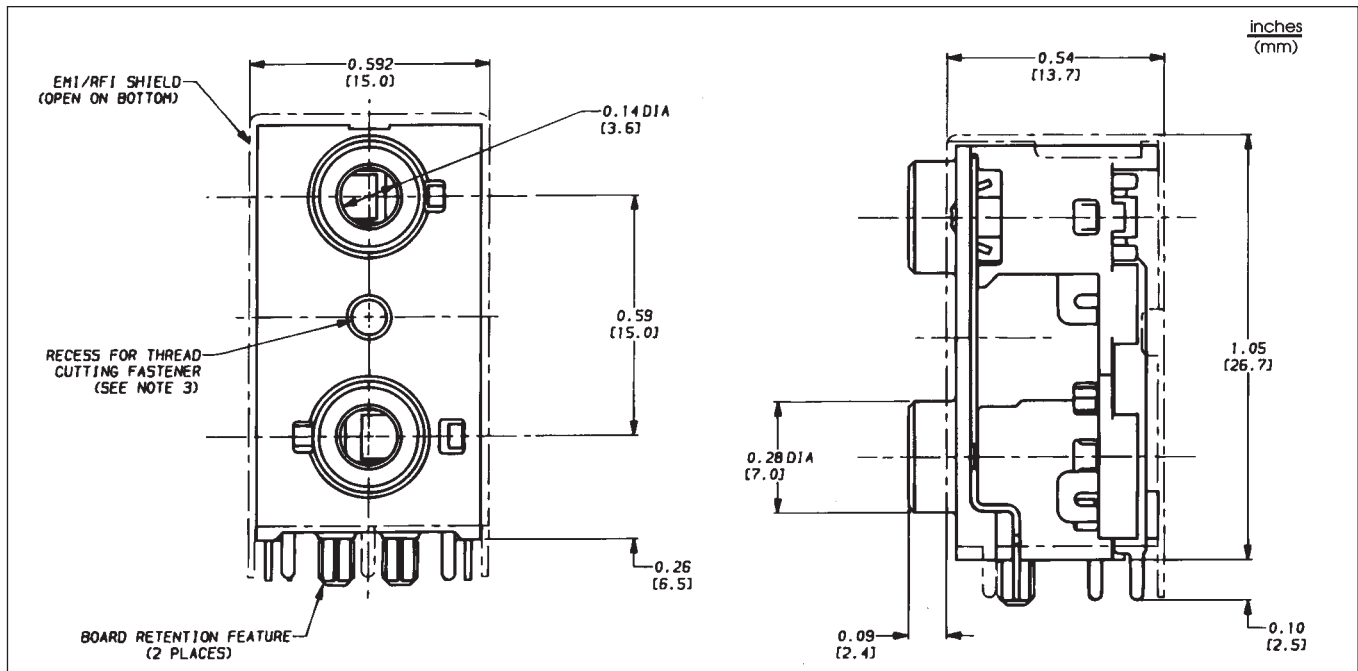
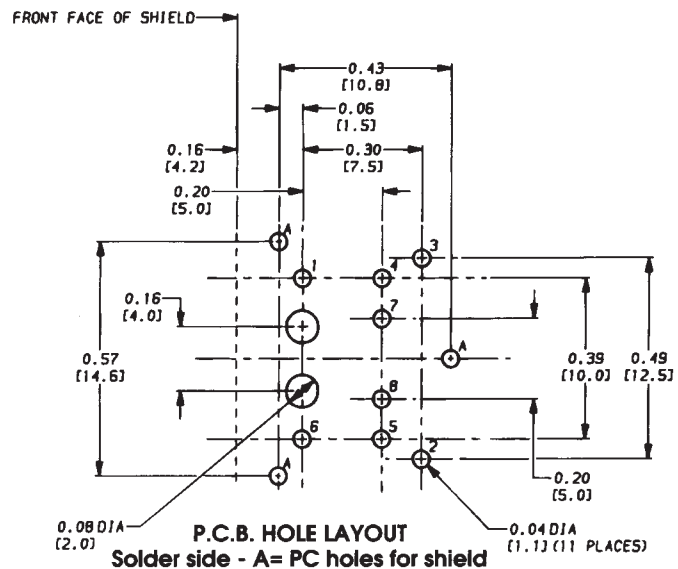

P.C.B. HOLE LAYOUT
Solder side - A= PC holes for shield

NOTES: □

1. Shield isolated from terminals 1 and 6. □
2. Width of all terminals = 0.032" (0.814mm). □
3. Use Camcar Textron S25 T8 TORX pan head "Duro-PT" □ thread cutting fastener of appropriate length or equivalent.

DIMENSIONS ARE FOR REFERENCE ONLY Inch
(mm)

NOTE: Contact your Switchcraft Representative for price and delivery.